

PRL-260BNT 2 ϕ Programmable NECL/TTL/Small Signal Frequency Divider

APPLICATIONS

- System clock simulation
- Low jitter ECL/TTL clock source
- SONET clock generator
- Low-Jitter Laser System Synchronization
- A Mini Modular Instrument™ for working with ECL and TTL circuits

FEATURES

- $f/2$ to $f/4096$ with independent 2 ϕ outputs
- Common divider f/n ($2 \leq n \leq 256$) has 8-bit resolution
- $\phi 1$ output= $(f/n)/(1, 2, 4 \text{ or } 8)$, for max ratio of 2048
- $\phi 2$ output= $(f/n)/(2, 4, 8 \text{ or } 16)$, for max ratio of 4096
- $\phi 1$ has complementary NECL & TTL outputs and square wave outputs except when the final divisor is 1
- $\phi 2$ has complementary NECL square wave outputs only
- Single-ended NECL, differential NECL, or AC-coupled sinewave inputs with internal $50 \Omega/V_{TT}$ terminations
- Additional logically ORed TTL input requires only 0.7 V
- Small Signal Comparator Input requires only 40 mV
- 20 ps typical edge jitter
- 50 ps typical skew between f/n & f/n NECL outputs
- 200 ps typical skew between f/n & f/n TTL outputs

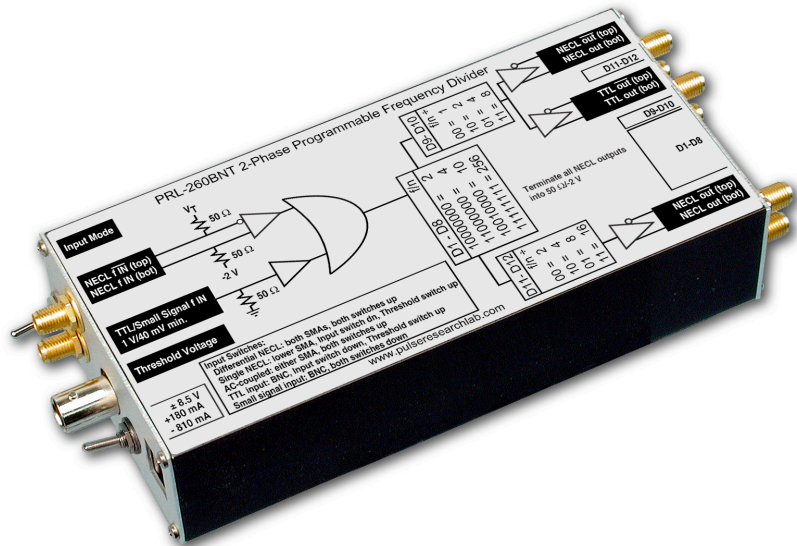

PRL-260BNT

- 1.25 GHz typical max. external clock input frequency
- Complementary NECL outputs drive 50Ω loads terminated to V_{TT} , AC-coupled or floating 50Ω loads
- Complementary TTL outputs drive long lines with or without 50Ω load terminations
- DC-coupled I/O's
- SMA I/O connectors except for TTL Input (BNC)
- Ready-to-use 1.3 x 2.9 x 6.1-in. module includes a $\pm 8.5V$ AC/DC adapter

DESCRIPTION

The PRL-260BNT is a DC-coupled, manually programmable, two-phase frequency divider with two sets of divided outputs, $\phi 1$ and $\phi 2$. It is capable of running at input clock frequencies in excess of 1 GHz and outputting divided TTL and NECL clock signals. The input frequency f is first divided down to f/n , where $2 \leq n \leq 256$, via D1-D8 of a ten-bit DIP switch. The f/n signal is further divided by 1, 2, 4, or 8 for the $\phi 1$ ECL and TTL outputs via D9 and D10, for a maximum ratio of 2048, and by 2, 4, 8 or 16 for the $\phi 2$ ECL output via D11 and D12 of a second two-bit DIP switch, for a maximum ratio of 4096. All outputs are synchronous with the input frequency and are square waves (50% duty cycle), except for $\phi 1$ output when the final divisor is set to 1 (D9-D10=00). When the final divisor is set to 1 the output pulse width is equal to the input pulse period. All outputs are complementary and will drive long lines. TTL outputs are back-matched and will drive terminated or unterminated loads. NECL outputs can drive 50Ω loads terminated into $-2 V$ or AC-coupled 50Ω loads.

A complementary NECL input is logically ORed with a TTL/Small Signal input, enabling the unit to accept TTL inputs, small signals (≥ 40 mV), single-ended or differential NECL inputs, or AC-coupled sinewave or other logic inputs. There is an Input Mode switch and a Threshold Voltage switch. For differential NECL inputs, both SMAs are used with both switches up. For single-ended NECL input the lower SMA is used with Input switch down and the Threshold switch up. For AC-coupled input either SMA can be used with both switches up. For TTL input the BNC input is used with the Input switch down and the Threshold switch up. For small signals the BNC input is used with both switches down. The NECL inputs are internally terminated to $50 \Omega/-2 V$ in the differential input mode, and the inverted input to $62 \Omega/-1.3 V$ in the single-ended input mode. The BNC input has a ground-referenced 50Ω termination, and the minimum signal required is only 0.75 V for TTL (switch up) or 40 mV for small signals (switch down).

The PRL-260BNT is ideal for applications where a frequency divider or prescaler is needed for triggering or down-sampling, and the multiple logic inputs and outputs make it extremely useful in mixed-logic environments. The two phases of output enable applications requiring two different ratios from a common reference frequency. Applications for the PRL-260BNT include data acquisition, test, measurement, R&D, and laser system synchronization.

The unit includes an AC adapter for ready-to-use convenience on the bench or in a system. All I/O connectors are SMA, except for the TTL/Small Signal input, which is BNC. The extruded aluminum housing is suitable for mounting with the optional brackets.



1234 Francisco Street, Torrance, CA 90502
Tel: 310-515-5330 Fax: 310-515-0068
Email: sales@pulseresearchlab.com
www.pulseresearchlab.com

***SPECIFICATIONS (0° C ≤ T_A ≤ 35°C)**

SYMBOL	PARAMETER	Min	Typ	Max	UNIT	Comments
R _{in}	External Clock Input Resistance	49.5	50	50.5	Ω	Except \bar{f} input in single-ended mode
V _{TT}	External Clock Input Termination Voltage	-2.2	-2 0	-1.8	V	ECL input TTL/Small Signal input
I _{DC}	DC Input Current		+165/ -790	+180/ -810	mA	
V _{DC}	DC Input Voltage	±7.5	±8.5	±12	V	
V _{AC}	AC/DC Adapter Input Voltage	103	115	127	V	
V _{IH}	External Clock Input Hi Level (R _{in} terminated to V _{TT})	-1.13 0.75 0.040	-0.9 0.7 0.035	-0.81 3 3	V	NECL (V _{TT} = -2 V) TTL (V _{TT} = 0 V) Small Signal (V _{TT} = 0 V)
V _{IL}	External Clock Input Lo Level (R _{in} terminated to V _{TT})	-1.95 -0.5 -0.5	-1.6 0 0	-1.48 0.5 0.01	V	NECL (V _{TT} = -2 V) TTL (V _{TT} = 0 V) Small Signal (V _{TT} = 0 V)
V _{OH}	Output Hi Level @ 100MHz (R _L terminated to V _{TT})	-1.13 2	-0.9 2.2	-0.81	V	NECL (V _{TT} = -2 V) TTL (V _{TT} = 0 V)
V _{OL}	Output Lo Level @ 100MHz (R _L terminated to V _{TT})	-1.95 -0.5	-1.6 0	-1.48 0.5	V	NECL (V _{TT} = -2 V) TTL (V _{TT} = 0 V)
t _{PLH1}	Propagation Delay to φ1 NECL output ↑		2500		ps	From Ext Clk input
t _{PLH2}	Propagation Delay to φ1 TTL output ↑		3750		ps	From Ext Clk input
t _{PLH3}	Propagation Delay to φ2 NECL output ↑		2500		ps	From Ext Clk input
t _r /t _{f1}	Rise/Fall Times (20%-80%), NECL outputs		600	700	ps	Note (1)
t _r /t _{f2}	Rise/Fall Times (10%-90%), TTL outputs		1100	1350	ps	
t _{SKEW1}	Skew ↔ φ1 NECL outputs		50	150	ps	
t _{SKEW2}	Skew ↔ φ1 TTL outputs		200	400	ps	
t _{SKEW3}	Skew ↔ φ1 NECL and TTL outputs		1300	1600	ps	
T _{SKEW4}	Skew ↔ φ1 and φ2 NECL outputs		50	150	ps	n≠1
f _{MAX In}	Max Input clock frequency	1000	1350	1500	MHz	
f _{MAX Out}	Max Output frequency	500 300	675 350		MHz	NECL Outputs TTL Outputs
	Size	1.3 x 2.9 x 6.1			in.	
	Weight	10			Oz	
	Shipping Weight	4			Lbs	

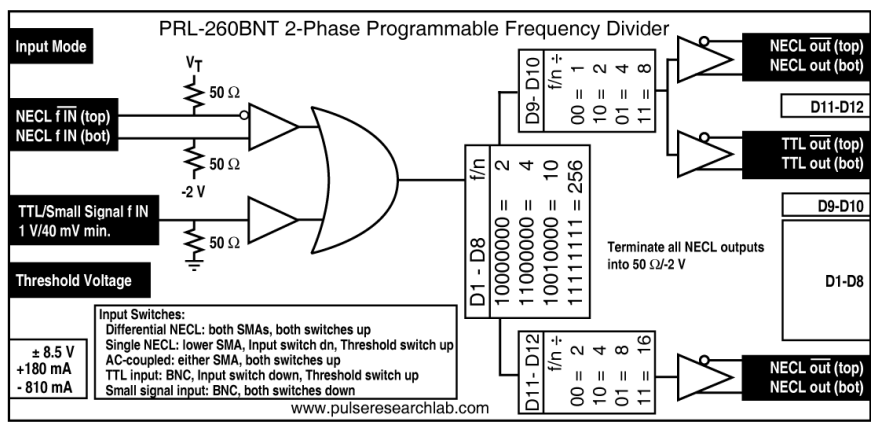

Fig. 1 PRL-260BNT Functional Block Diagram

otherwise, output waveform distortion and rise time degradation will occur. Use the PRL-ACT-50, Dual Ch. AC-Coupled 50 Ω Termination, for the 50 Ω/V_{TT} termination. Use the PRL-SC-104 or PRL-ACX-12dB (0.1 μf DC block and 12 dB AC-coupled attenuator, respectively) for connection of NECL signals to 50 Ω input oscilloscopes.

*All dynamic NECL measurements are made with outputs terminated into 50 Ω /V_{TT}, using the PRL-550NQ4X, four channel NECL Terminator, connected to a 50 Ω input sampling oscilloscope. TTL outputs are terminated to 50 Ω.

Notes:
(1). The output rise and fall times of each NECL channel are measured with its complementary output terminated into 50 Ω/V_{TT}. An unused complementary 50 Ω output must be either terminated into 50 Ω /V_{TT} or AC coupled into a 50 Ω load;



PRL-260BNT Divisor/Switch Settings with Sample Frequencies

(divide f/n by 1, 2, 4, 8 or 16 for final output frequency)

f/n	D1	D2	D3	D4	D5	D6	D7	D8	f=500.0000	f=622.0800	f=644.53125	f/n	D1	D2	D3	D4	D5	D6	D7	D8	f=500.0000	f=622.0800	f=644.53125	
2	1	0	0	0	0	0	0	0	250.0000	311.0400	322.26563	65	0	0	0	0	0	0	1	0	7.6923	9.5705	9.91587	
3	0	1	0	0	0	0	0	0	166.6667	207.3600	214.84375	66	1	0	0	0	0	0	1	0	7.5758	9.4255	9.76563	
4	1	1	0	0	0	0	0	0	125.0000	155.5200	161.13281	67	0	1	0	0	0	0	0	1	0	7.4627	9.2848	9.61987
5	0	0	1	0	0	0	0	0	100.0000	124.4160	128.90625	68	1	1	0	0	0	0	1	0	7.3529	9.1482	9.47840	
6	1	0	1	0	0	0	0	0	83.3333	103.6800	107.42188	69	0	0	1	0	0	0	1	0	7.2464	9.0157	9.34103	
7	0	1	1	0	0	0	0	0	71.4286	88.8686	92.07589	70	1	0	1	0	0	0	1	0	7.1429	8.8869	9.20759	
8	1	1	1	0	0	0	0	0	62.5000	77.7600	80.56641	71	0	1	1	0	0	0	1	0	7.0423	8.7617	9.07790	
9	0	0	0	1	0	0	0	0	55.5556	69.1200	71.61458	72	1	1	1	0	0	0	1	0	6.9444	8.6400	8.95182	
10	1	0	0	1	0	0	0	0	50.0000	62.2080	64.45313	73	0	0	0	1	0	0	1	0	6.8493	8.5216	8.82920	
11	0	1	0	1	0	0	0	0	45.4545	56.5527	58.59375	74	1	0	0	1	0	0	1	0	6.7568	8.4065	8.70988	
12	1	1	0	1	0	0	0	0	41.6667	51.8400	53.71094	75	0	1	0	1	0	0	1	0	6.6667	8.2944	8.59375	
13	0	0	1	1	0	0	0	0	38.4615	47.8523	49.57933	76	1	1	0	1	0	0	1	0	6.5789	8.1853	8.48067	
14	1	0	1	1	0	0	0	0	35.7143	44.4343	46.03795	77	0	0	1	1	0	0	1	0	6.4935	8.0790	8.37054	
15	0	1	1	1	0	0	0	0	33.3333	41.4720	42.96875	78	1	0	1	1	0	0	1	0	6.4103	7.9754	8.26322	
16	1	1	1	1	0	0	0	0	31.2500	38.8800	40.28320	79	0	1	1	1	0	0	1	0	6.3291	7.8744	8.15862	
17	0	0	0	1	0	0	0	0	29.4118	36.5929	37.91360	80	1	1	1	1	0	0	1	0	6.2500	7.7760	8.05664	
18	1	0	0	0	1	0	0	0	27.7778	34.5600	35.80729	81	0	0	0	0	1	0	1	0	6.1728	7.6800	7.95718	
19	0	1	0	0	1	0	0	0	26.3158	32.7411	33.92270	82	1	0	0	0	1	0	1	0	6.0976	7.5863	7.86014	
20	1	1	0	0	1	0	0	0	25.0000	31.1040	32.22656	83	0	1	0	0	1	0	1	0	6.0241	7.4949	7.76544	
21	0	0	1	0	1	0	0	0	23.8095	29.6229	30.69196	84	1	1	0	0	1	0	1	0	5.9524	7.4057	7.67299	
22	1	0	1	0	1	0	0	0	22.7273	28.2764	29.29688	85	0	0	1	0	1	0	1	0	5.8824	7.3186	7.58272	
23	0	1	1	0	1	0	0	0	21.7391	27.0470	28.02310	86	1	0	1	0	1	0	1	0	5.8140	7.2335	7.49455	
24	1	1	1	0	1	0	0	0	20.8333	25.9200	26.85547	87	0	1	1	0	1	0	1	0	5.7471	7.1503	7.40841	
25	0	0	0	1	1	0	0	0	20.0000	24.8832	25.78125	88	1	1	1	0	1	0	1	0	5.6818	7.0691	7.32422	
26	1	0	0	1	1	0	0	0	19.2308	23.9262	24.78966	89	0	0	0	1	1	0	1	0	5.6180	6.9897	7.24192	
27	0	1	0	1	1	0	0	0	18.5185	23.0400	23.87153	90	1	0	0	1	1	0	1	0	5.5556	6.9120	7.16146	
28	1	1	0	1	1	0	0	0	17.8571	22.2171	23.01897	91	0	1	0	1	1	0	1	0	5.4945	6.8360	7.08276	
29	0	0	1	1	1	0	0	0	17.2414	21.4510	22.22522	92	1	1	0	1	1	0	1	0	5.4348	6.7617	7.00577	
30	1	0	1	1	1	0	0	0	16.6667	20.7360	21.48438	93	0	0	1	1	1	0	1	0	5.3763	6.6890	6.93044	
31	0	1	1	1	1	0	0	0	16.1290	20.0671	20.79133	94	1	0	1	1	1	0	1	0	5.3191	6.6179	6.85672	
32	1	1	1	1	1	0	0	0	15.6250	19.4400	20.14160	95	0	1	1	1	1	0	1	0	5.2632	6.5482	6.78454	
33	0	0	0	0	0	1	0	0	15.1515	18.8509	19.53125	96	1	1	1	1	1	0	1	0	5.2083	6.4800	6.71387	
34	1	0	0	0	0	1	0	0	14.7059	18.2965	18.95680	97	0	0	0	0	0	1	1	0	5.1546	6.4132	6.64465	
35	0	1	0	0	0	1	0	0	14.2857	17.7737	18.41518	98	1	0	0	0	0	1	1	0	5.1020	6.3478	6.57685	
36	1	1	0	0	0	1	0	0	13.8889	17.2800	17.90365	99	0	1	0	0	0	1	1	0	5.0505	6.2836	6.51042	
37	0	0	1	0	0	1	0	0	13.5135	16.8130	17.41976	100	1	1	0	0	0	1	1	0	5.0000	6.2208	6.44531	
38	1	0	1	0	0	1	0	0	13.1579	16.3705	16.96135	101	0	0	1	0	0	1	1	0	4.9505	6.1592	6.38150	
39	0	1	1	0	0	1	0	0	12.8205	15.9508	16.52644	102	1	0	1	0	0	1	1	0	4.9020	6.0988	6.31893	
40	1	1	1	0	0	1	0	0	12.5000	15.5520	16.11328	103	0	1	1	0	0	1	1	0	4.8544	6.0396	6.25758	
41	0	0	0	1	0	1	0	0	12.1951	15.1727	15.72027	104	1	1	1	0	0	1	1	0	4.8077	5.9815	6.19742	
42	1	0	0	1	0	1	0	0	11.9048	14.8114	15.34598	105	0	0	0	1	0	1	1	0	4.7619	5.9246	6.13839	
43	0	1	0	1	0	1	0	0	11.6279	14.4670	14.98910	106	1	0	0	1	0	1	1	0	4.7170	5.8687	6.08048	
44	1	1	0	1	0	1	0	0	11.3636	14.1382	14.64844	107	0	1	0	1	0	1	1	0	4.6729	5.8138	6.02366	
45	0	0	1	1	0	1	0	0	11.1111	13.8240	14.32292	108	1	1	0	1	0	1	1	0	4.6296	5.7600	5.96788	
46	1	0	1	1	0	1	0	0	10.8696	13.5235	14.01155	109	0	0	1	1	0	1	1	0	4.5872	5.7072	5.91313	
47	0	1	1	1	0	1	0	0	10.6383	13.2357	13.71343	110	1	0	1	1	0	1	1	0	4.5455	5.6553	5.85938	
48	1	1	1	1	0	1	0	0	10.4167	12.9600	13.42773	111	0	1	1	1	0	1	1	0	4.5045	5.6043	5.80659	
49	0	0	0	0	1	1	0	0	10.2041	12.6955	13.15370	112	1	1	1	1	0	1	1	0	4.4643	5.5543	5.75474	
50	1	0	0	0	1	1	0	0	10.0000	12.4416	12.89063	113	0	0	0	0	1	1	1	0	4.4248	5.5051	5.70382	
51	0	1	0	0	1	1	0	0	9.8039	12.1976	12.63787	114	1	0	0	0	1	1	1	0	4.3860	5.4568	5.65378	
52	1	1	0	0	1	1	0	0	9.6154	11.9631	12.39483	115	0	1	0	0	1	1	1	0	4.3478	5.4094	5.60462	
53	0	0	1	0	1	1	0	0	9.4340	11.7374	12.16097	116	1	1	0	0	1	1	1	0	4.3103	5.3628	5.55630	
54	1	0	1	0	1	1	0	0	9.2593	11.5200	11.93576	117	0	0	1	0	1	1	1	0	4.2735	5.3169	5.50881	
55	0	1	1	0	1	1	0	0	9.0909	11.3105	11.71875	118	1	0	1	0	1	1	1	0	4.2373	5.2719	5.46213	
56	1	1	1	0	1	1	0	0	8.9286	11.1086	11.50949	119	0	1	1	0	1	1	1	0	4.2017	5.2276	5.41623	
57	0	0	0	1	1	1	0	0	8.7719	10.9137	11.30757	120	1	1	1	0	1	1	1	0	4.1667	5.1840	5.37109	
58	1	0	0	1	1	1	0	0	8.6207	10.7255	11.11261	121	0	0	0	1	1	1	1	0	4.1322	5.1412	5.32670	
59	0	1	0	1	1	1	0	0	8.4746	10.5437	10.92426	122	1	0	0	1	1	1	1	0	4.0984	5.0990	5.28304	
60	1	1	0	1	1	1	0	0	8.3333	10.3680	10.74219	123	0	1	0	1	1	1	1	0	4.0650	5.0576	5.24009	
61	0	0	1	1	1	1	0	0	8.1967	10.1980	10.56609	124	1	1	0	1	1	1	1	0	4.0323	5.0168	5.19783	
62	1	0	1	1	1	1	0	0	8.0645	10.0335	10.39567	125	0	0	1	1	1	1	1	0	4.0000	4.9766	5.15625	
63	0	1	1	1	1	1	0	0	7.9365	9.8743	10.23065	126	1	0	1	1	1	1	1	0	3.9683	4.9371	5.11533	
64	1	1	1	1	1	1	0	0	7.8125	9.7200	10.07080	127	0	1	1	1	1	1	1	0	3.9370	4.8983	5.07505	
												128	1	1	1	1	1	1	1	0	3.9063	4.8600	5.03540	



1234 Francisco Street, Torrance, CA 90502
 Tel: 310-515-5330 Fax: 310-515-0068
 Email:

PRL-260NT Divisor/Switch Settings with Sample Frequencies

(divide f/n by 1, 2, 4, 8 or 16 for final output frequency)

f/n	D1	D2	D3	D4	D5	D6	D7	D8	f=500.0000	f=622.0800	f=644.53125	f/n	D1	D2	D3	D4	D5	D6	D7	D8	f=500.0000	f=622.0800	f=644.53125
129	0	0	0	0	0	0	0	1	3.8760	4.8223	4.99637	193	0	0	0	0	0	0	1	1	2.5907	3.2232	3.33954
130	1	0	0	0	0	0	0	1	3.8462	4.7852	4.95793	194	1	0	0	0	0	0	1	1	2.5773	3.2066	3.32233
131	0	1	0	0	0	0	0	1	3.8168	4.7487	4.92009	195	0	1	0	0	0	0	1	1	2.5641	3.1902	3.30529
132	1	1	0	0	0	0	0	1	3.7879	4.7127	4.88281	196	1	1	0	0	0	0	1	1	2.5510	3.1739	3.28842
133	0	0	1	0	0	0	0	1	3.7594	4.6773	4.84610	197	0	0	1	0	0	0	1	1	2.5381	3.1578	3.27173
134	1	0	1	0	0	0	0	1	3.7313	4.6424	4.80993	198	1	0	1	0	0	0	1	1	2.5253	3.1418	3.25521
135	0	1	1	0	0	0	0	1	3.7037	4.6080	4.77431	199	0	1	1	0	0	0	1	1	2.5126	3.1260	3.23885
136	1	1	1	0	0	0	0	1	3.6765	4.5741	4.73920	200	1	1	1	0	0	0	1	1	2.5000	3.1104	3.22266
137	0	0	0	1	0	0	0	1	3.6496	4.5407	4.70461	201	0	0	0	1	0	0	1	1	2.4876	3.0949	3.20662
138	1	0	0	1	0	0	0	1	3.6232	4.5078	4.67052	202	1	0	0	1	0	0	1	1	2.4752	3.0796	3.19075
139	0	1	0	1	0	0	0	1	3.5971	4.4754	4.63692	203	0	1	0	1	0	0	1	1	2.4631	3.0644	3.17503
140	1	1	0	1	0	0	0	1	3.5714	4.4434	4.60379	204	1	1	0	1	0	0	1	1	2.4510	3.0494	3.15947
141	0	0	1	1	0	0	0	1	3.5461	4.4119	4.57114	205	0	0	1	1	0	0	1	1	2.4390	3.0345	3.14405
142	1	0	1	1	0	0	0	1	3.5211	4.3808	4.53895	206	1	0	1	1	0	0	1	1	2.4272	3.0198	3.12879
143	0	1	1	1	0	0	0	1	3.4965	4.3502	4.50721	207	0	1	1	1	0	0	1	1	2.4155	3.0052	3.11368
144	1	1	1	1	0	0	0	1	3.4722	4.3200	4.47591	208	1	1	1	1	0	0	1	1	2.4038	2.9908	3.09871
145	0	0	0	0	1	0	0	1	3.4483	4.2902	4.44504	209	0	0	0	0	1	0	1	1	2.3923	2.9765	3.08388
146	1	0	0	0	1	0	0	1	3.4247	4.2608	4.41460	210	1	0	0	0	1	0	1	1	2.3810	2.9623	3.06920
147	0	1	0	0	1	0	0	1	3.4014	4.2318	4.38457	211	0	1	0	0	1	0	1	1	2.3697	2.9482	3.05465
148	1	1	0	0	1	0	0	1	3.3784	4.2032	4.35494	212	1	1	0	0	1	0	1	1	2.3585	2.9343	3.04024
149	0	0	1	0	1	0	0	1	3.3557	4.1750	4.32571	213	0	0	1	0	1	0	1	1	2.3474	2.9206	3.02597
150	1	0	0	1	0	1	0	1	3.3333	4.1472	4.29688	214	1	0	1	0	1	0	1	1	2.3364	2.9069	3.01183
151	0	1	1	0	1	0	0	1	3.3113	4.1197	4.26842	215	0	1	1	0	1	0	1	1	2.3256	2.8934	2.99782
152	1	1	1	0	1	0	0	1	3.2895	4.0926	4.24034	216	1	1	1	0	1	0	1	1	2.3148	2.8800	2.98394
153	0	0	0	1	1	0	0	1	3.2680	4.0659	4.21262	217	0	0	0	1	1	0	1	1	2.3041	2.8667	2.97019
154	1	0	0	1	1	0	0	1	3.2468	4.0395	4.18527	218	1	0	0	1	1	0	1	1	2.2936	2.8536	2.95657
155	0	1	0	1	1	0	0	1	3.2258	4.0134	4.15827	219	0	1	0	1	1	0	1	1	2.2831	2.8405	2.94307
156	1	1	0	1	1	0	0	1	3.2051	3.9877	4.13161	220	1	1	0	1	1	0	1	1	2.2727	2.8276	2.92969
157	0	0	1	1	1	0	0	1	3.1847	3.9623	4.10529	221	0	0	1	1	1	0	1	1	2.2624	2.8148	2.91643
158	1	0	1	1	1	0	0	1	3.1646	3.9372	4.07931	222	1	0	1	1	1	0	1	1	2.2523	2.8022	2.90329
159	0	1	1	1	1	0	0	1	3.1447	3.9125	4.05366	223	0	1	1	1	1	0	1	1	2.2422	2.7896	2.89027
160	1	1	1	1	1	0	0	1	3.1250	3.8880	4.02832	224	1	1	1	1	1	0	1	1	2.2321	2.7771	2.87737
161	0	0	0	0	0	1	0	1	3.1056	3.8639	4.00330	225	0	0	0	0	0	1	1	1	2.2222	2.7648	2.86458
162	1	0	0	0	0	1	0	1	3.0864	3.8400	3.97859	226	1	0	0	0	0	1	1	1	2.2124	2.7526	2.85191
163	0	1	0	0	0	1	0	1	3.0675	3.8164	3.95418	227	0	1	0	0	0	1	1	1	2.2026	2.7404	2.83934
164	1	1	0	0	0	1	0	1	3.0488	3.7932	3.93007	228	1	1	0	0	0	1	1	1	2.1930	2.7284	2.82689
165	0	0	1	0	0	1	0	1	3.0303	3.7702	3.90625	229	0	0	1	0	0	1	1	1	2.1834	2.7165	2.81455
166	1	0	1	0	0	1	0	1	3.0120	3.7475	3.88272	230	1	0	1	0	0	1	1	1	2.1739	2.7047	2.80231
167	0	1	1	0	0	1	0	1	2.9940	3.7250	3.85947	231	0	1	1	0	0	1	1	1	2.1645	2.6930	2.79018
168	1	1	1	0	0	1	0	1	2.9762	3.7029	3.83650	232	1	1	1	0	0	1	1	1	2.1552	2.6814	2.77815
169	0	0	0	0	1	0	1	1	2.9586	3.6809	3.81379	233	0	0	0	0	1	0	1	1	2.1459	2.6699	2.76623
170	1	0	0	0	1	0	1	1	2.9412	3.6593	3.79136	234	1	0	0	1	0	1	1	1	2.1368	2.6585	2.75441
171	0	1	0	1	0	1	0	1	2.9240	3.6379	3.76919	235	0	1	0	1	0	1	1	1	2.1277	2.6471	2.74269
172	1	1	0	1	0	1	0	1	2.9070	3.6167	3.74727	236	1	1	0	1	0	1	1	1	2.1186	2.6359	2.73106
173	0	0	1	1	0	1	0	1	2.8902	3.5958	3.72561	237	0	0	1	1	0	1	1	1	2.1097	2.6248	2.71954
174	1	0	1	1	0	1	0	1	2.8736	3.5752	3.70420	238	1	0	1	1	0	1	1	1	2.1008	2.6138	2.70811
175	0	1	1	1	0	1	0	1	2.8571	3.5547	3.68304	239	0	1	1	1	0	1	1	1	2.0921	2.6028	2.69678
176	1	1	1	1	0	1	0	1	2.8409	3.5345	3.66211	240	1	1	1	1	0	1	1	1	2.0833	2.5920	2.68555
177	0	0	0	0	1	1	0	1	2.8249	3.5146	3.64142	241	0	0	0	0	1	1	1	1	2.0747	2.5812	2.67440
178	1	0	0	0	1	1	0	1	2.8090	3.4948	3.62096	242	1	0	0	0	1	1	1	1	2.0661	2.5706	2.66335
179	0	1	0	0	1	1	0	1	2.7933	3.4753	3.60073	243	0	1	0	0	1	1	1	1	2.0576	2.5600	2.65239
180	1	1	0	0	1	1	0	1	2.7778	3.4560	3.58073	244	1	1	0	0	1	1	1	1	2.0492	2.5495	2.64152
181	0	0	1	0	1	1	0	1	2.7624	3.4369	3.56095	245	0	0	1	0	1	1	1	1	2.0408	2.5391	2.63074
182	1	0	1	0	1	1	0	1	2.7473	3.4180	3.54138	246	1	0	1	0	1	1	1	1	2.0325	2.5288	2.62005
183	0	1	1	0	1	1	0	1	2.7322	3.3993	3.52203	247	0	1	1	0	1	1	1	1	2.0243	2.5185	2.60944
184	1	1	1	0	1	1	0	1	2.7174	3.3809	3.50289	248	1	1	1	0	1	1	1	1	2.0161	2.5084	2.59892
185	0	0	0	1	1	1	0	1	2.7027	3.3626	3.48395	249	0	0	0	1	1	1	1	1	2.0080	2.4983	2.58848
186	1	0	0	1	1	1	0	1	2.6882	3.3445	3.46522	250	1	0	0	1	1	1	1	1	2.0000	2.4883	2.57813
187	0	1	0	1	1	1	0	1	2.6738	3.3266	3.44669	251	0	1	0	1	1	1	1	1	1.9920	2.4784	2.56785
188	1	1	0	1	1	1	0	1	2.6596	3.3089	3.42836	252	1	1	0	1	1	1	1	1	1.9841	2.4686	2.55766
189	0	0	1	1	1	1	0	1	2.6455	3.2914	3.41022	253	0	0	1	1	1	1	1	1	1.9763	2.4588	2.54755
190	1	0	1	1	1	1	0	1	2.6316	3.2741	3.39227	254	1	0	1	1	1	1	1	1	1.9685	2.4491	2.53752
191	0	1	1	1	1	1	0	1	2.6178	3.2570	3.37451	255	0	1	1	1	1	1	1	1	1.9608	2.4395	2.52757
192	1	1	1	1	1	1	0	1	2.6042	3.2400	3.35693	256	1	1	1	1	1	1	1	1	1.9531	2.4300	2.51770



1234 Francisco Street, Torrance, CA 90502
 Tel: 310-515-5330 Fax: 310-515-0068
 Email: sales@pulseresearchlab.com
[www.pulsere](http://www.pulseresearchlab.com)