

# PRL-174ANT NECL/TTL PROGRAMMABLE CLOCK GENERATOR

## APPLICATIONS

- System Clock Simulation
- Xtal Clock Replacement
- Frequency Margining
- Low Jitter ECL/TTL Clock Source
- SONET Clock Generator
- An Essential Lab Tool for Working with ECL and TTL Circuits

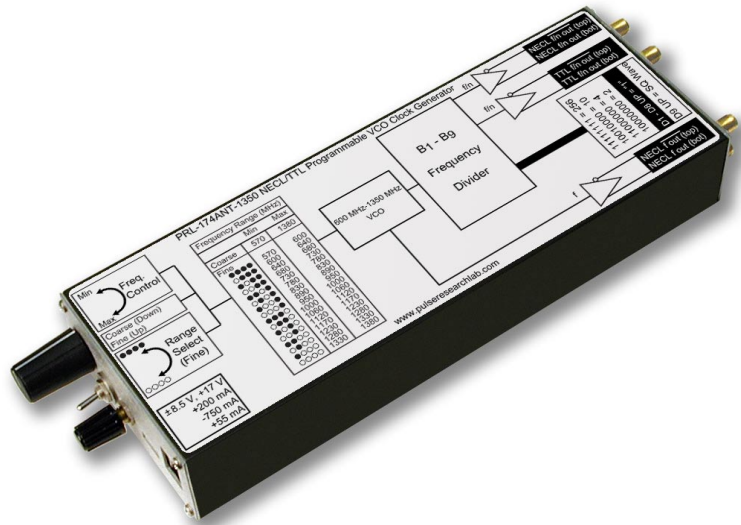

## FEATURES

- 1.2 MHz to 1.35 GHz Frequency Range
- 100 ppm Typical Setting Resolution and Short-term Stability
- NECL  $f$  and  $\bar{f}$  Outputs
- NECL and TTL  $f/n$  and  $\bar{f}/n$  Outputs
- 20 ps Typical Edge Jitter

## FEATURES (cont'd)

- 50 ps Typical Skew Between  $f/n$  &  $\bar{f}/n$  NECL Outputs
- 500 ps Typical Skew Between  $f/n$  &  $\bar{f}/n$  TTL outputs
- Complementary NECL/TTL Outputs drive 50  $\Omega$  loads
- DC-Coupled Outputs with SMA Connectors
- Ready-to-Use 1.3 x 2.9 x 8.1-in. Module includes AC/DC Adapter

## DESCRIPTION

The PRL-174ANT is a manually programmable clock source module, designed specifically for applications where continuously variable frequency with Xtal-like precision is required. Substituting for a hard-to-find crystal oscillator in system test and frequency margining in telecommunication network checkout are two of the most important applications.

The internal VCO frequency  $f$  is continuously variable from 600 MHz to 1.35 GHz using a 10-turn pot in the coarse control mode. In the fine control mode, a 16-position rotary switch first divides the 750 MHz frequency span into 16 increments, and the 10-turn pot further fine tunes each segment and sets the VCO frequency to within 100 ppm of the desired value. The 100 ppm setting and stability remain valid over a short term period of at least a half hour, provided the ambient temperature variation is less than 2° C and the VCO frequency is set above 650MHz. Stability over 12 hours with  $\pm 2^\circ$  C temperature variation is typically 250 ppm.

The VCO frequency  $f$  is then divided by 2 to 256 through D1-D8 of a 9-position DIP switch. D9 further divides the  $f/n$  outputs by 2, extending the maximum division to 512 and providing square wave outputs. The maximum output frequency available is greater than 1.35GHz and the minimum less than 1.2MHz. The PRL-174ANT has complementary NECL  $f$  and  $\bar{f}$  outputs and  $f/n$  and  $\bar{f}/n$  NECL and TTL outputs.

The NECL outputs are designed for driving 50  $\Omega$  loads terminated into -2 V and they can also drive AC coupled or floating 50  $\Omega$  loads. The 50  $\Omega$  back-terminated TTL outputs can drive long 50  $\Omega$  lines with or without 50  $\Omega$  terminations and are usable up to 250 MHz.

Applications of the PRL-174ANT include Xtal clock replacement, frequency margining, precision clock for high speed digital systems, low jitter clock source for testing A/D's, SONET Clock generator, and Basic Lab Tool for working with high speed NECL and TTL/CMOS circuits. A binary table showing the codes for all the possible division ratios is given in Table I.

The PRL-174ANT is housed in a 1.3 x 2.9 x 8.1-in. extruded aluminum enclosure and is supplied with a  $\pm 8.5$  V, +17 V AC/DC Adapter

1234 Francisco Street, Torrance, CA 90502  
Tel: 310-515-5330 Fax: 310-515-0068  
Email: [sales@pulseresearchlab.com](mailto:sales@pulseresearchlab.com)  
[www.pulseresearchlab.com](http://www.pulseresearchlab.com)

## \*SPECIFICATIONS (0° C ≤ T<sub>A</sub> ≤ 35°C)

SYMBOL	PARAMETER	Min	Typ	Max	UNIT	Comments
I <sub>DC</sub>	DC Input Current		+185/-700 45	+200/-750 55	mA	±8.5 V +17 V
V <sub>DC</sub>	DC Input Voltage	±7.5 +17	±8.5 +18	±12 +20	V	
V <sub>AC</sub>	AC/DC Adapter Input Voltage	103	115	127	V	
t <sub>r</sub> /t <sub>f1</sub>	Rise/Fall Times (20%-80%), NECL outputs		400	750	ps	Note (1)
t <sub>r</sub> /t <sub>f2</sub>	Rise/Fall Times (10%-90%), TTL outputs		1000	1300	ps	
t <sub>SKEW1</sub>	Skew f ↔ f̄ Outputs		30	60	ps	
t <sub>SKEW2</sub>	Skew f/n ↔ f̄ / n ECL Outputs		50	100	ps	
t <sub>SKEW3</sub>	Skew f/n ↔ f̄ / n TTL Outputs		500	850	ps	
T <sub>SKEW4</sub>	Skew f/n ECL ↔ f/n TTL Outputs		1000	1250	ps	n≠1
f <sub>MAX</sub> f <sub>MIN</sub>	Max. Output Clock Frequency Min. Output Clock Frequency	1350	1375 570	1400 600	MHz	
f <sub>MAX</sub> /f <sub>MIN</sub>		2	2.3			
f/n <sub>MAX</sub>	Max NECL f/n Output Frequency Max TTL f/n Output Frequency	675 200	687.5 250	700	MHz	Note (2)
f/n <sub>MIN</sub>	Min. Output Frequency		1.12	1.2	MHz	
Δf1	Short-Term Frequency Drift over 1/2 hr.		100	250	ppm	ΔT <sub>A</sub> < 2°C (3)
Δf2	Long-Term Frequency Drift over 12 hrs		250	500	ppm	ΔT <sub>A</sub> < 2°C
Δf3	Initial Frequency Drift w/in 1 min. after power-on		5000		ppm	ΔT <sub>A</sub> < 2°C
	Frequency Jitter, Peak-to-Peak		20	25	ps	
	Size	1.3 x 2.9 x 8.1			in.	
	Weight	10			Oz	

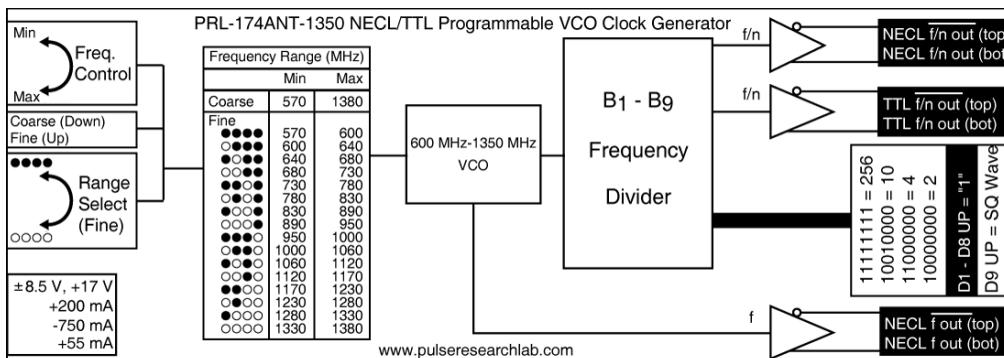

**Fig. 1 PRL-174ANT-1350 Top Cover Decal**

\*All dynamic NECL measurements are made with outputs terminated into 50 Ω/-2 V, using the PRL-550NQ4X, 4 channel NECL Terminator, connected to a 50 Ω input sampling oscilloscope. TTL outputs are terminated with 50 Ω.

Notes:

(1) The rise and fall times of the NECL outputs are measured with all outputs terminated into 50 Ω/-2 V. An unused complementary output

must be either terminated into 50 Ω/-2 V or AC coupled into a 50 Ω load; otherwise, output waveform distortion and rise time degradation will occur. Use the PRL-550NQ4X, four channel NECL Terminator, for the 50 Ω/V<sub>TT</sub> termination and for connection to 50 Ω input oscilloscopes, when DC coupling is necessary. Otherwise, use the PRL-ACT-50, dual AC coupled 50Ω-termination for terminating unused outputs and the PRL-SC-104, 0.1 μf DC block, for AC coupling into a 50 Ω load or scope. The PRL-ACX-12dB, AC coupled 12 dB attenuator, can also be used either for termination or for connection to an oscilloscope.

(2) In Normal mode, the pulse width of the f/n outputs is equal to the period of the VCO frequency, varying from 741 ps to 1.67 ns as the VCO frequency is changed from 1.35 GHz to 600 MHz. In Square Wave mode (Bit 9 up), the pulse width is twice the f/n clock period. For optimum performance, use the square wave output mode for TTL outputs. Beyond 250 MHz, reduced swings of the TTL outputs no longer comply with the standard Hi and Lo levels of 2 V and 0.8 V, respectively.

(3) After 1 hour warm up and VCO out frequency f ≥ 650 MHz. For f < 650 MHz, Δf1 and Δf2 may exceed 250 ppm and 500 ppm, respectively.

# PRL-174ANT-1350 Divisor Table w/Base Frequencies

f/n	D1	D2	D3	D4	D5	D6	D7	D8	f=600.0000	f=622.0800	f=1350.00000	f/n	D1	D2	D3	D4	D5	D6	D7	D8	f=600.0000	f=622.0800	f=1350.00000
21	0	0	0	0	0	0	0	0	300.0000	311.0400	675.0000	65	0	0	0	0	0	0	1	0	9.2308	9.5705	20.7692
30	1	0	0	0	0	0	0	0	200.0000	207.3600	450.0000	66	1	0	0	0	0	0	1	0	9.0909	9.4255	20.4545
41	1	0	0	0	0	0	0	0	150.0000	155.5200	337.5000	67	0	1	0	0	0	0	1	0	8.9552	9.2848	20.1493
50	0	1	0	0	0	0	0	0	120.0000	124.4160	270.0000	68	1	1	0	0	0	0	1	0	8.8235	9.1482	19.8529
61	0	1	0	0	0	0	0	0	100.0000	103.6800	225.0000	69	0	0	1	0	0	0	1	0	8.6957	9.0157	19.5652
70	1	1	0	0	0	0	0	0	85.7143	88.8686	192.8571	70	1	0	1	0	0	0	1	0	8.5714	8.8869	19.2857
81	1	1	1	0	0	0	0	0	75.0000	77.7600	168.7500	71	0	1	1	0	0	0	1	0	8.4507	8.7617	19.0141
90	0	0	1	0	0	0	0	0	66.6667	69.1200	150.0000	72	1	1	1	0	0	0	1	0	8.3333	8.6400	18.7500
101	0	0	1	0	0	0	0	0	60.0000	62.2080	135.0000	73	0	0	0	1	0	0	1	0	8.2192	8.5216	18.4932
110	1	0	1	0	0	0	0	0	54.5455	56.5527	122.7273	74	1	0	0	1	0	0	1	0	8.1081	8.4065	18.2432
121	1	0	1	0	0	0	0	0	50.0000	51.8400	112.5000	75	0	1	0	1	0	0	1	0	8.0000	8.2944	18.0000
130	0	1	1	0	0	0	0	0	46.1538	47.8523	103.8462	76	1	1	0	1	0	0	1	0	7.8947	8.1853	17.7632
141	0	1	1	0	0	0	0	0	42.8571	44.4343	96.4286	77	0	0	1	1	0	0	1	0	7.7922	8.0790	17.5325
150	1	1	1	0	0	0	0	0	40.0000	41.4720	90.0000	78	1	0	1	1	0	0	1	0	7.6923	7.9754	17.3077
161	1	1	1	0	0	0	0	0	37.5000	38.8800	84.3750	79	0	1	1	1	0	0	1	0	7.5949	7.8744	17.0886
170	0	0	0	1	0	0	0	0	35.2941	36.5929	79.4118	80	1	1	1	1	0	0	1	0	7.5000	7.7760	16.8750
181	0	0	0	1	0	0	0	0	33.3333	34.5600	75.0000	81	0	0	0	0	1	0	1	0	7.4074	7.6800	16.6667
190	1	0	0	1	0	0	0	0	31.5789	32.7411	71.0526	82	1	0	0	0	1	0	1	0	7.3171	7.5863	16.4634
201	1	0	0	1	0	0	0	0	30.0000	31.1040	67.5000	83	0	1	0	0	1	0	1	0	7.2289	7.4949	16.2651
210	0	1	0	1	0	0	0	0	28.5714	29.6229	64.2857	84	1	1	0	0	1	0	1	0	7.1429	7.4057	16.0714
221	0	1	0	1	0	0	0	0	27.2727	28.2764	61.3636	85	0	0	1	0	1	0	1	0	7.0588	7.3186	15.8824
230	1	1	0	1	0	0	0	0	26.0870	27.0470	58.6957	86	1	0	1	0	1	0	1	0	6.9767	7.2335	15.6977
241	1	1	0	1	0	0	0	0	25.0000	25.9200	56.2500	87	0	1	1	0	1	0	1	0	6.8966	7.1503	15.5172
250	0	0	1	1	0	0	0	0	24.0000	24.8832	54.0000	88	1	1	1	0	1	0	1	0	6.8182	7.0691	15.3409
261	0	0	1	1	0	0	0	0	23.0769	23.9262	51.9231	89	0	0	0	1	1	0	1	0	6.7416	6.9897	15.1685
270	1	0	1	1	0	0	0	0	22.2222	23.0400	50.0000	90	1	0	0	1	1	0	1	0	6.6667	6.9120	15.0000
281	1	0	1	1	0	0	0	0	21.4286	22.2171	48.2143	91	0	1	0	1	1	0	1	0	6.5934	6.8360	14.8352
290	0	1	1	1	0	0	0	0	20.6897	21.4510	46.5517	92	1	1	0	1	1	0	1	0	6.5217	6.7617	14.6739
301	0	1	1	1	0	0	0	0	20.0000	20.7360	45.0000	93	0	0	1	1	1	0	1	0	6.4516	6.6890	14.5161
310	1	1	1	1	0	0	0	0	19.3548	20.0671	43.5484	94	1	0	1	1	1	0	1	0	6.3830	6.6179	14.3617
321	1	1	1	1	0	0	0	0	18.7500	19.4400	42.1875	95	0	1	1	1	1	0	1	0	6.3158	6.5482	14.2105
330	0	0	0	0	1	0	0	0	18.1818	18.8509	40.9091	96	1	1	1	1	1	0	1	0	6.2500	6.4800	14.0625
341	0	0	0	0	1	0	0	0	17.6471	18.2965	39.7059	97	0	0	0	0	0	1	1	0	6.1856	6.4132	13.9175
350	1	0	0	0	1	0	0	0	17.1429	17.7737	38.5714	98	1	0	0	0	0	1	1	0	6.1224	6.3478	13.7755
361	1	0	0	0	1	0	0	0	16.6667	17.2800	37.5000	99	0	1	0	0	0	1	1	0	6.0606	6.2836	13.6364
370	0	1	0	0	1	0	0	0	16.2162	16.8130	36.4865	100	1	1	0	0	0	1	1	0	6.0000	6.2208	13.5000
381	0	1	0	0	1	0	0	0	15.7895	16.3705	35.5263	101	0	0	1	0	0	1	1	0	5.9406	6.1592	13.3663
390	1	1	0	0	1	0	0	0	15.3846	15.9508	34.6154	102	1	0	1	0	0	1	1	0	5.8824	6.0988	13.2353
401	1	1	0	0	1	0	0	0	15.0000	15.5520	33.7500	103	0	1	1	0	0	1	1	0	5.8252	6.0396	13.1068
410	0	0	1	0	1	0	0	0	14.6341	15.1727	32.9268	104	1	1	1	0	0	1	1	0	5.7692	5.9815	12.9808
421	0	0	1	0	1	0	0	0	14.2857	14.8114	32.1429	105	0	0	0	1	0	1	1	0	5.7143	5.9246	12.8571
430	1	0	1	0	1	0	0	0	13.9535	14.4670	31.3953	106	1	0	0	1	0	1	1	0	5.6604	5.8687	12.7358
441	1	0	1	0	1	0	0	0	13.6364	14.1382	30.6818	107	0	1	0	1	0	1	1	0	5.6075	5.8138	12.6168
450	0	1	1	0	1	0	0	0	13.3333	13.8240	30.0000	108	1	1	0	1	0	1	1	0	5.5556	5.7600	12.5000
461	0	1	1	0	1	0	0	0	13.0435	13.5235	29.3478	109	0	0	1	1	0	1	1	0	5.5046	5.7072	12.3853
470	1	1	1	0	1	0	0	0	12.7660	13.2357	28.7234	110	1	0	1	1	0	1	1	0	5.4545	5.6553	12.2727
481	1	1	1	0	1	0	0	0	12.5000	12.9600	28.1250	111	0	1	1	1	0	1	1	0	5.4054	5.6043	12.1622
490	0	0	0	1	1	0	0	0	12.2449	12.6955	27.5510	112	1	1	1	1	0	1	1	0	5.3571	5.5543	12.0536
501	0	0	0	1	1	0	0	0	12.0000	12.4416	27.0000	113	0	0	0	0	1	1	1	0	5.3097	5.5051	11.9469
510	1	0	0	1	1	0	0	0	11.7647	12.1976	26.4706	114	1	0	0	0	1	1	1	0	5.2632	5.4568	11.8421
521	1	0	0	1	1	0	0	0	11.5385	11.9631	25.9615	115	0	1	0	0	1	1	1	0	5.2174	5.4094	11.7391
530	0	1	0	1	1	0	0	0	11.3208	11.7374	25.4717	116	1	1	0	0	1	1	1	0	5.1724	5.3628	11.6379
541	0	1	0	1	1	0	0	0	11.1111	11.5200	25.0000	117	0	0	1	0	1	1	1	0	5.1282	5.3169	11.5385
550	1	1	0	1	1	0	0	0	10.9091	11.3105	24.5455	118	1	0	1	0	1	1	1	0	5.0847	5.2719	11.4407
561	1	1	0	1	1	0	0	0	10.7143	11.1086	24.1071	119	0	1	1	0	1	1	1	0	5.0420	5.2276	11.3445
570	0	0	1	1	1	0	0	0	10.5263	10.9137	23.6842	120	1	1	1	0	1	1	1	0	5.0000	5.1840	11.2500
581	0	0	1	1	1	0	0	0	10.3448	10.7255	23.2759	121	0	0	0	1	1	1	1	0	4.9587	5.1412	11.1570
590	1	0	1	1	1	0	0	0	10.1695	10.5437	22.8814	122	1	0	0	1	1	1	1	0	4.9180	5.0990	11.0656
601	1	0	1	1	1	0	0	0	10.0000	10.3680	22.5000	123	0	1	0	1	1	1	1	0	4.8780	5.0576	10.9756
610	0	1	1	1	1	0	0	0	9.8361	10.1980	22.1311	124	1	1	0	1	1	1	1	0	4.8387	5.0168	10.8871
621	0	1	1	1	1	0	0	0	9.6774	10.0335	21.7742	125	0	0	1	1	1	1	1	0	4.8000	4.9766	10.8000
630	1	1	1	1	1	0	0	0	9.5238	9.8743	21.4286	126	1	0	1	1	1	1	1	0	4.7619	4.9371	10.7143
641	1	1	1	1	1	0	0	0	9.3750	9.7200	21.0938	127	0	1	1	1	1	1	1	0	4.7244	4.8983	10.6299
												128	1	1	1	1	1	1	1	0	4.6875	4.8600	10.5469

# PRL-174ANT-1350 Divisor Table w/Base Frequencies

f/n	D1	D2	D3	D4	D5	D6	D7	D8	f=600.0000	f=622.0800	f=1350.00000	f/n	D1	D2	D3	D4	D5	D6	D7	D8	f=600.0000	f=622.0800	f=1350.00000
129	0	0	0	0	0	0	0	1	4.6512	4.8223	10.4651	193	0	0	0	0	0	0	1	1	3.1088	3.2232	6.9948
130	1	0	0	0	0	0	0	1	4.6154	4.7852	10.3846	194	1	0	0	0	0	0	1	1	3.0928	3.2066	6.9588
131	0	1	0	0	0	0	0	1	4.5802	4.7487	10.3053	195	0	1	0	0	0	0	1	1	3.0769	3.1902	6.9231
132	1	1	0	0	0	0	0	1	4.5455	4.7127	10.2273	196	1	1	0	0	0	0	1	1	3.0612	3.1739	6.8878
133	0	0	1	0	0	0	0	1	4.5113	4.6773	10.1504	197	0	0	1	0	0	0	1	1	3.0457	3.1578	6.8528
134	1	0	1	0	0	0	0	1	4.4776	4.6424	10.0746	198	1	0	1	0	0	0	1	1	3.0303	3.1418	6.8182
135	0	1	1	0	0	0	0	1	4.4444	4.6080	10.0000	199	0	1	1	0	0	0	1	1	3.0151	3.1260	6.7839
136	1	1	1	0	0	0	0	1	4.4118	4.5741	9.9265	200	1	1	1	0	0	0	1	1	3.0000	3.1104	6.7500
137	0	0	0	1	0	0	0	1	4.3796	4.5407	9.8540	201	0	0	0	1	0	0	1	1	2.9851	3.0949	6.7164
138	1	0	0	1	0	0	0	1	4.3478	4.5078	9.7826	202	1	0	0	1	0	0	1	1	2.9703	3.0796	6.6832
139	0	1	0	1	0	0	0	1	4.3165	4.4754	9.7122	203	0	1	0	1	0	0	1	1	2.9557	3.0644	6.6502
140	1	1	0	1	0	0	0	1	4.2857	4.4434	9.6429	204	1	1	0	1	0	0	1	1	2.9412	3.0494	6.6176
141	0	0	1	1	0	0	0	1	4.2553	4.4119	9.5745	205	0	0	1	1	0	0	1	1	2.9268	3.0345	6.5854
142	1	0	1	1	0	0	0	1	4.2254	4.3808	9.5070	206	1	0	1	1	0	0	1	1	2.9126	3.0198	6.5534
143	0	1	1	1	0	0	0	1	4.1958	4.3502	9.4406	207	0	1	1	1	0	0	1	1	2.8986	3.0052	6.5217
144	1	1	1	1	0	0	0	1	4.1667	4.3200	9.3750	208	1	1	1	1	0	0	1	1	2.8846	2.9908	6.4904
145	0	0	0	0	1	0	0	1	4.1379	4.2902	9.3103	209	0	0	0	0	1	0	1	1	2.8708	2.9765	6.4593
146	1	0	0	0	1	0	0	1	4.1096	4.2608	9.2466	210	1	0	0	0	1	0	1	1	2.8571	2.9623	6.4286
147	0	1	0	0	1	0	0	1	4.0816	4.2318	9.1837	211	0	1	0	0	1	0	1	1	2.8436	2.9482	6.3981
148	1	1	0	0	1	0	0	1	4.0541	4.2032	9.1216	212	1	1	0	0	1	0	1	1	2.8302	2.9343	6.3679
149	0	0	1	0	1	0	0	1	4.0268	4.1750	9.0604	213	0	0	1	0	1	0	1	1	2.8169	2.9206	6.3380
150	1	0	1	0	1	0	0	1	4.0000	4.1472	9.0000	214	1	0	1	0	1	0	1	1	2.8037	2.9069	6.3084
151	0	1	1	0	1	0	0	1	3.9735	4.1197	8.9404	215	0	1	1	0	1	0	1	1	2.7907	2.8934	6.2791
152	1	1	1	0	1	0	0	1	3.9474	4.0926	8.8816	216	1	1	1	0	1	0	1	1	2.7778	2.8800	6.2500
153	0	0	0	1	1	0	0	1	3.9216	4.0659	8.8235	217	0	0	0	1	1	0	1	1	2.7650	2.8667	6.2212
154	1	0	0	1	1	0	0	1	3.8961	4.0395	8.7662	218	1	0	0	1	1	0	1	1	2.7523	2.8536	6.1927
155	0	1	0	1	1	0	0	1	3.8710	4.0134	8.7097	219	0	1	0	1	1	0	1	1	2.7397	2.8405	6.1644
156	1	1	0	1	1	0	0	1	3.8462	3.9877	8.6538	220	1	1	0	1	1	0	1	1	2.7273	2.8276	6.1364
157	0	0	1	1	1	0	0	1	3.8217	3.9623	8.5987	221	0	0	1	1	1	0	1	1	2.7149	2.8148	6.1086
158	1	0	1	1	1	0	0	1	3.7975	3.9372	8.5443	222	1	0	1	1	1	0	1	1	2.7027	2.8022	6.0811
159	0	1	1	1	1	0	0	1	3.7736	3.9125	8.4906	223	0	1	1	1	1	0	1	1	2.6906	2.7896	6.0538
160	1	1	1	1	1	0	0	1	3.7500	3.8880	8.4375	224	1	1	1	1	1	0	1	1	2.6786	2.7771	6.0268
161	0	0	0	0	0	1	0	1	3.7267	3.8639	8.3851	225	0	0	0	0	0	1	1	1	2.6667	2.7648	6.0000
162	1	0	0	0	0	1	0	1	3.7037	3.8400	8.3333	226	1	0	0	0	0	1	1	1	2.6549	2.7526	5.9735
163	0	1	0	0	0	1	0	1	3.6810	3.8164	8.2822	227	0	1	0	0	0	1	1	1	2.6432	2.7404	5.9471
164	1	1	0	0	0	1	0	1	3.6585	3.7932	8.2317	228	1	1	0	0	0	1	1	1	2.6316	2.7284	5.9211
165	0	0	1	0	0	1	0	1	3.6364	3.7702	8.1818	229	0	0	1	0	0	1	1	1	2.6201	2.7165	5.8952
166	1	0	1	0	0	1	0	1	3.6145	3.7475	8.1325	230	1	0	1	0	0	1	1	1	2.6087	2.7047	5.8696
167	0	1	1	0	0	1	0	1	3.5928	3.7250	8.0838	231	0	1	1	0	0	1	1	1	2.5974	2.6930	5.8442
168	1	1	1	0	0	1	0	1	3.5714	3.7029	8.0357	232	1	1	1	0	0	1	1	1	2.5862	2.6814	5.8190
169	0	0	0	1	0	1	0	1	3.5503	3.6809	7.9882	233	0	0	0	1	0	1	1	1	2.5751	2.6699	5.7940
170	1	0	0	1	0	1	0	1	3.5294	3.6593	7.9412	234	1	0	0	1	0	1	1	1	2.5641	2.6585	5.7692
171	0	1	0	1	0	1	0	1	3.5088	3.6379	7.8947	235	0	1	0	1	0	1	1	1	2.5532	2.6471	5.7447
172	1	1	0	1	0	1	0	1	3.4884	3.6167	7.8488	236	1	1	0	1	0	1	1	1	2.5424	2.6359	5.7203
173	0	0	1	1	0	1	0	1	3.4682	3.5958	7.8035	237	0	0	1	1	0	1	1	1	2.5316	2.6248	5.6962
174	1	0	1	1	0	1	0	1	3.4483	3.5752	7.7586	238	1	0	1	1	0	1	1	1	2.5210	2.6138	5.6723
175	0	1	1	1	0	1	0	1	3.4286	3.5547	7.7143	239	0	1	1	1	0	1	1	1	2.5105	2.6028	5.6485
176	1	1	1	1	0	1	0	1	3.4091	3.5345	7.6705	240	1	1	1	1	0	1	1	1	2.5000	2.5920	5.6250
177	0	0	0	0	1	1	0	1	3.3898	3.5146	7.6271	241	0	0	0	0	1	1	1	1	2.4896	2.5812	5.6017
178	1	0	0	0	1	1	0	1	3.3708	3.4948	7.5843	242	1	0	0	0	1	1	1	1	2.4793	2.5706	5.5785
179	0	1	0	0	1	1	0	1	3.3520	3.4753	7.5419	243	0	1	0	0	1	1	1	1	2.4691	2.5600	5.5556
180	1	1	0	0	1	1	0	1	3.3333	3.4560	7.5000	244	1	1	0	0	1	1	1	1	2.4590	2.5495	5.5328
181	0	0	1	0	1	1	0	1	3.3149	3.4369	7.4586	245	0	0	1	0	1	1	1	1	2.4490	2.5391	5.5102
182	1	0	1	0	1	1	0	1	3.2967	3.4180	7.4176	246	1	0	1	0	1	1	1	1	2.4390	2.5288	5.4878
183	0	1	1	0	1	1	0	1	3.2787	3.3993	7.3770	247	0	1	1	0	1	1	1	1	2.4291	2.5185	5.4656
184	1	1	1	0	1	1	0	1	3.2609	3.3809	7.3370	248	1	1	1	0	1	1	1	1	2.4194	2.5084	5.4435
185	0	0	0	1	1	1	0	1	3.2432	3.3626	7.2973	249	0	0	0	1	1	1	1	1	2.4096	2.4983	5.4217
186	1	0	0	1	1	1	0	1	3.2258	3.3445	7.2581	250	1	0	0	1	1	1	1	1	2.4000	2.4883	5.4000
187	0	1	0	1	1	1	0	1	3.2086	3.3266	7.2193	251	0	1	0	1	1	1	1	1	2.3904	2.4784	5.3785
188	1	1	0	1	1	1	0	1	3.1915	3.3089	7.1809	252	1	1	0	1	1	1	1	1	2.3810	2.4686	5.3571
189	0	0	1	1	1	1	0	1	3.1746	3.2914	7.1429	253	0	0	0	1	1	1	1	1	2.3715	2.4588	5.3360
190	1	0	1	1	1	1	0	1	3.1579	3.2741	7.1053	254	1	0	1	1	1	1	1	1	2.3622	2.4491	5.3150
191	0	1	1	1	1	1	0	1	3.1414	3.2570	7.0681	255	0	1	1	1	1	1	1	1	2.3529	2.4395	5.2941
192	1	1	1	1	1	1	0	1	3.1250	3.2400	7.0313	256	1	1	1	1	1	1	1	1	2.3438	2.4300	5.2734