

GIGADAPTERS, SURFACE-MOUNT TO THROUGH-HOLE ADAPTERS WITH DC TO 3+ GHZ BANDWIDTH

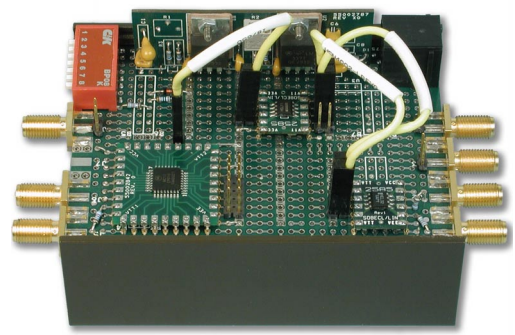
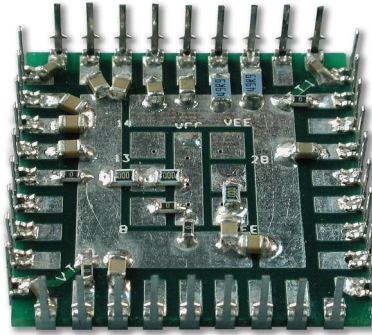
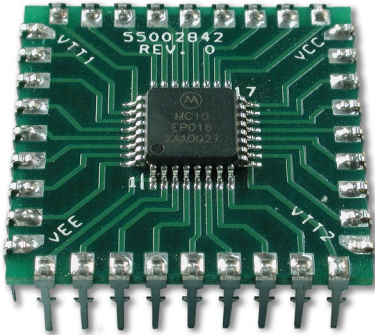

Applications

- Prototyping GHz Logic Functions
- High Speed Digital Communications
- Wireless RF Microwave Circuits and Systems
- Wideband Linear Circuits
- High Speed Device Evaluation

Features

- DC to 3+ GHz Operation
- Many supported package types (see table)
- Optimized for logic, linear, and RF devices
- Multi Layer Board with power and GND Planes
- On Board I/O and Decoupling Component sites
- Custom Motherboards for GHz Prototyping
- Low Cost and Easy to use

Description

The Gigadapters are a family of surface-mount adapters that convert many popular SO, SSO, PLCC, and QFP packages to through-hole footprints with standard, 100-mil pin spacing. Our patented design preserves signal fidelity for low-noise and/or high-speed devices, and some of these adapters can operate at frequencies up to 3+ GHz. At present, there are 27 models—20 optimized for logic and linear devices, and 7 optimized for RF devices.

These adapters are specifically designed for building GHz logic circuits and RF Microwave circuits, prototype systems and evaluation fixtures. Three reusable Gigadapter motherboards are available for the construction of these systems and test fixtures. For less critical applications, these adapters can also be used with CMOS, TTL and linear devices using standard PC boards with through-hole pads on 100-mil centers.

Performance

Devices on smaller Gigadapters, such as the MC10EL16 differential receiver (SO8), have been clocked in excess of 3 GHz. The pictured device is an MC10EP016 8-bit programmable frequency divider (QFP-32). Using the Gigadapter motherboard and 50 Ohm coaxial interconnect modules as shown, this circuit ran at 1.2 GHz, limited only by the MC10EP016 device.

The Patented Gigadapter Design

The Gigadapter design is based on the concept of matched impedance, with controlled impedance I/O lines connected to every device pin. Each adapter has a multi-layer PC board with a specific surface-mount device footprint on one side. On the other side, pads are strategically located under the device footprint for mounting of critical components, such as decoupling capacitors, termination resistors and other series and/or shunt components. These components have very short connections to the device footprint above via feed-through holes as shown in **Figure 2** and **Figure 4**.

Furthermore, each PC board has power and ground planes. These planes are connected to extra pins (in addition to the device pins) for connections to the motherboard. Therefore, none of the device pins needs to be committed before a device is installed. Typical PC layout patterns for an SO8 and SO8RF adapters are shown in **Figure 1** through **Figure 4**, and the corresponding physical adapters with components installed on both sides of the adapters are shown in **Figure 5** through **Figure 8**.

1234 Francisco Street
Torrance, CA 90502
Tel: 310-515-5330
Fax: 310-515-0068



sales@pulseresearchlab.com
www.pulseresearchlab.com
Products covered by
U.S. Patents 6,407,652 or 6,265,952

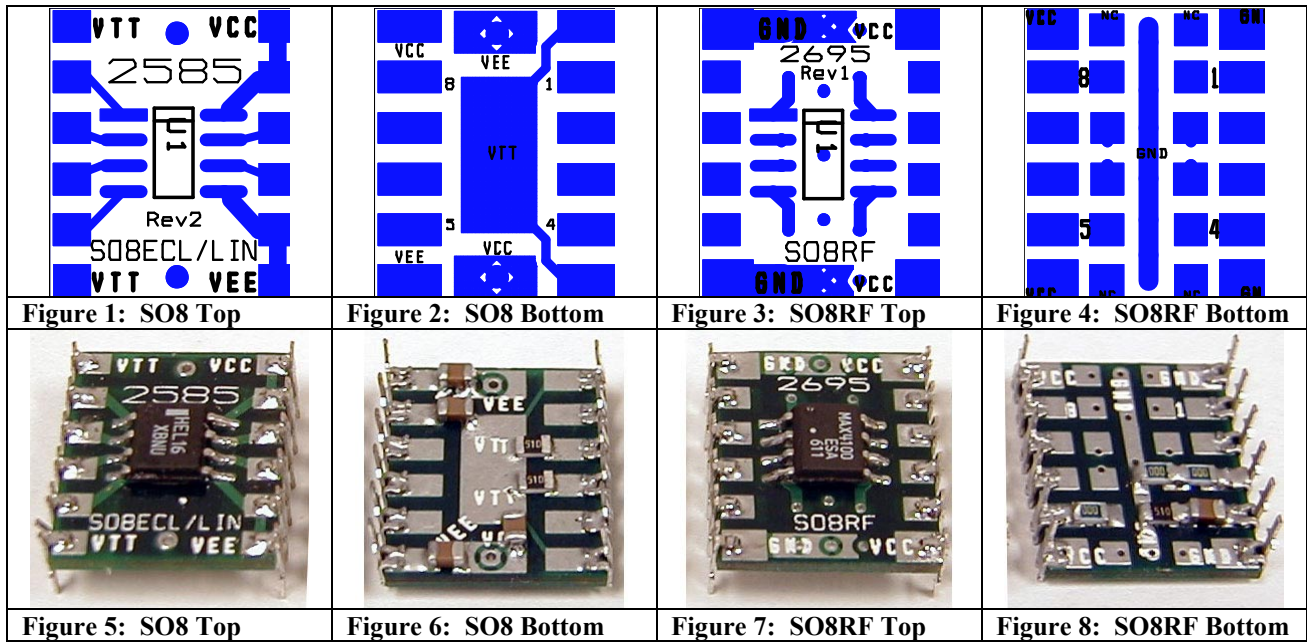

Gigadapter Dimensions Table

Subject to footprint pitch and width specifications listed below, the Gigadapters will typically support the following devices:

- “SO” adapters support devices described as SO, and SOIC
- “SSO” adapters support devices described as SSO, SSOP, MSSOP, and TSSOP
- “LCC” adapters support devices described as LCC, CLCC, and PLCC
- “QFP” adapters support devices described as QFP, HLQFP, HQFP, HTQFP, HVQFP, LQFP, MQFP, TQFP, or VQFP

Model	Footprint Pitch		Footprint Width				Adapter Size			
			Min		Max		mm		in	
	mm	in	mm	in	mm	in	W	L	W	L
SO-8	1.270	0.050	2.540	0.100	7.366	0.290	12.700	15.240	0.500	0.600
SO-8RF	1.270	0.050	2.540	0.100	7.366	0.290	12.700	15.240	0.500	0.600
SO-14	1.270	0.050	2.540	0.100	7.366	0.290	12.700	22.860	0.500	0.900
SO-14RF	1.270	0.050	2.540	0.100	7.366	0.290	12.700	22.860	0.500	0.900
SO-16	1.270	0.050	2.540	0.100	7.366	0.290	12.700	25.400	0.500	1.000
SO-16RF	1.270	0.050	2.540	0.100	7.366	0.290	12.700	25.400	0.500	1.000
SO-20	1.270	0.050	6.604	0.260	11.811	0.465	25.400	30.480	1.000	1.200
SO-20RF	1.270	0.050	6.604	0.260	11.811	0.465	25.400	30.480	1.000	1.200
SSO-8	0.650	0.026	3.556	0.140	7.620	0.300	12.700	15.240	0.500	0.600
SSO-14	0.650	0.026	3.556	0.140	7.620	0.300	12.700	22.860	0.500	0.900
SSO-16	0.650	0.026	3.556	0.140	7.620	0.300	12.700	25.400	0.500	1.000
SSO-20	0.650	0.026	4.572	0.180	9.144	0.360	25.400	30.480	1.000	1.200
SSO-24	0.650	0.026	4.572	0.180	9.144	0.360	25.400	35.560	1.000	1.400
SSO-24RF	0.635	0.025	3.429	0.135	7.620	0.300	25.400	35.560	1.000	1.400
SSO-28	0.650	0.026	4.572	0.180	9.144	0.360	25.400	40.640	1.000	1.600
SSO28-RF	0.635	0.025	3.429	0.135	7.620	0.300	25.400	37.465	1.000	1.475
SSO-30	0.650	0.026	4.572	0.180	9.144	0.360	25.400	43.180	1.000	1.700
SSO-30RF	0.650	0.026	3.810	0.150	7.874	0.310	25.400	37.465	1.000	1.475
SSO-48	0.500	0.020	5.842	0.230	9.398	0.370	25.400	66.040	1.000	2.600
LCC-20	1.270	0.050	10.000	0.395			25.146	25.146	0.990	0.990
LCC-28	1.270	0.050	12.570	0.495			25.146	25.146	0.990	0.990
QFP-32-0.5	0.500	0.020	7.100	0.280			25.400	25.400	1.000	1.000
QFP-32-0.8	0.800	0.032	9.200	0.360			25.400	25.400	1.000	1.000
QFP-44-0.8	0.800	0.032	13.450	0.530			48.260	48.260	1.900	1.900
QFP-48-0.5	0.500	0.020	9.200	0.360			48.260	48.260	1.900	1.900
QFP-52-0.65	0.650	0.026	12.200	0.470			48.260	48.260	1.900	1.900
QFP-64-0.5	0.500	0.020	12.200	0.480			48.260	48.260	1.900	1.900

Please visit www.pulseresearchlab.com/gigadapters for information on Gigadapter motherboards and accessories.